



T3 Modular Switchback Signal Pods - Front

DNL.T3.10200



Thank you for choosing DENALI

We know you would rather be riding your bike than wrenching on it, so we go the extra mile to make sure our instructions are clear and as easy to understand as possible. If you have any questions, comments, or suggestions don't hesitate to give our gear experts a call at 401.360.2550 or visit WWW.DENALIELECTRONICS.COM

Please Read Before Installing

DENALI products should always be installed by a qualified motorcycle technician. If you are unsure of your ability to properly install a product, please have the product installed by your local motorcycle dealer. DENALI takes no responsibility for damages caused by improper installation. **Caution:** When installing electronics it is extremely important to pay close attention to how wires are routed, especially when mounting products to the front fender, front forks, or fairing of your motorcycle. Always be sure to turn the handlebars fully left, fully right, and fully compress the suspension to ensure the wires will not bind and have enough slack for your motorcycle to operate properly.

Installation Tips

We strongly recommend using medium strength liquid thread locker on all screws, nuts, and bolts. It is also important to ensure that all hardware is tightened to the proper torque specifications as listed in your owner's manual. For included accessory hardware please refer to the default torque specifications provided below. Inspect all hardware after the first 30 miles to ensure proper torque specifications are maintained.

Bolt Size	in-lbs	ft-lbs	Nm
M3	10.0 in-lbs	-	1.0 Nm
M4	23.0 in-lbs	-	2.5 Nm
M5	44.5 in-lbs	3.5 ft-lbs	5.0 Nm
M6	78.0 in-lbs	6.5 ft-lbs	9.0 Nm
M8	-	13.5 ft-lbs	18.0 Nm
M10	-	30.0 ft-lbs	41.0 Nm
M12	-	52.0 ft-lbs	71.0 Nm

Hardware Sizing Guide

Not sure what size bolt you have? Use this ruler to measure screws, bolts, spacers, etc. Remember, the length of a screw or bolt is measured from the start of the "mounting surface" to the end of the screw, so only include the screw head when measuring countersunk screws.

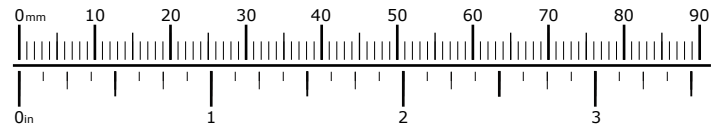

What's In The Box?

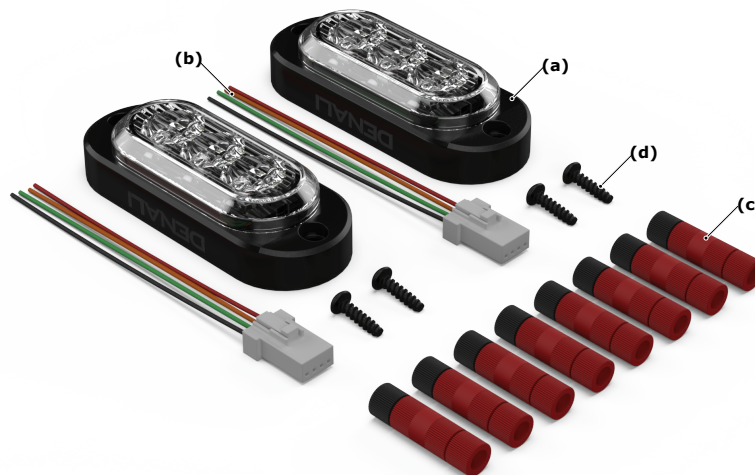

Kit Contents

- (a) T3 Pod.....Qty 2
- (b) Wiring Pigtail.....Qty 2
- (c) Posi-Tap Connector.....Qty 8
- (d) Self Tapping Screw.....Qty 4

1. Connecting To Vehicle Harness (Single Intensity DRL)

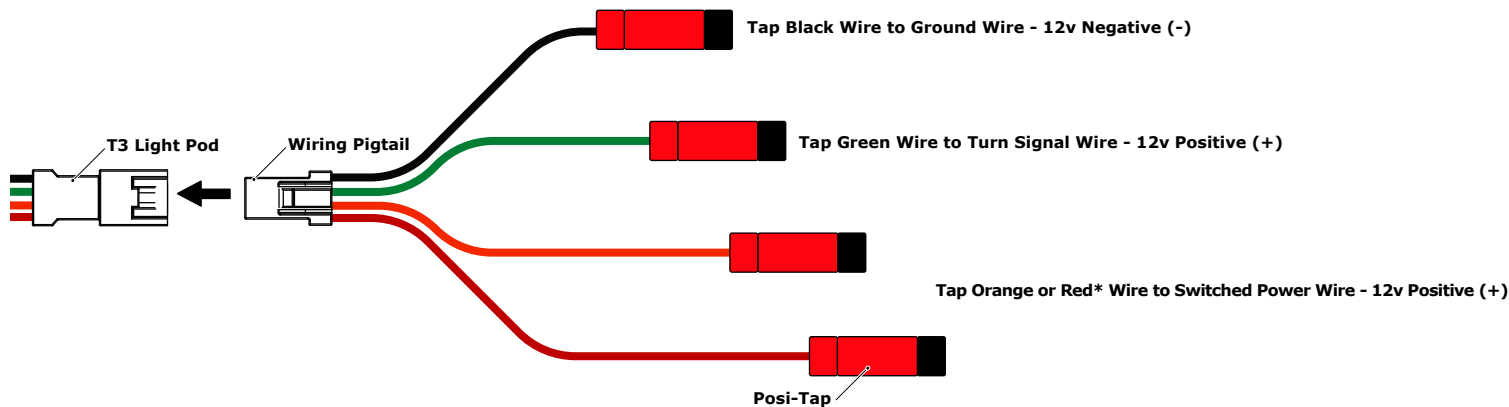

1.1 - Wiring The Pigtail

We reinvented the common turn signal to create a shockingly bright amber turn signal with an integrated dual-intensity white DRL.

Step One: Route the cable from the T3 Light Pod (a) into the motorcycle to the area of the factory head light & turn signal connectors.

Step Two: Identify the vehicle's factory Ground, Turn Signal and Switcher Power Wires. Refer to *Section 3.1* for a list of common motorcycle wire colors, or use a voltmeter or multimeter to assist in identifying the correct wires.

Step Three: Use Posi-Tap connectors (d) to wire the Pigtail (b) to the wires identified in the previous step.

- Tap the Black Wire to Vehicle Ground Wire
- Tap the Green Wire to the Vehicle Turn Signal Wire
- Tap the Orange or Red* Wire to Vehicle Switched Power Wire

***Note:** Use the Red Wire for a e-mark approved DRL. Use the Orange Wire for full intensity.

Step Four: Plug the Pigtail (b) into the connector of the T3 Light Pod (a).

2. Connecting To Vehicle Harness (Dual Intensity DRL)

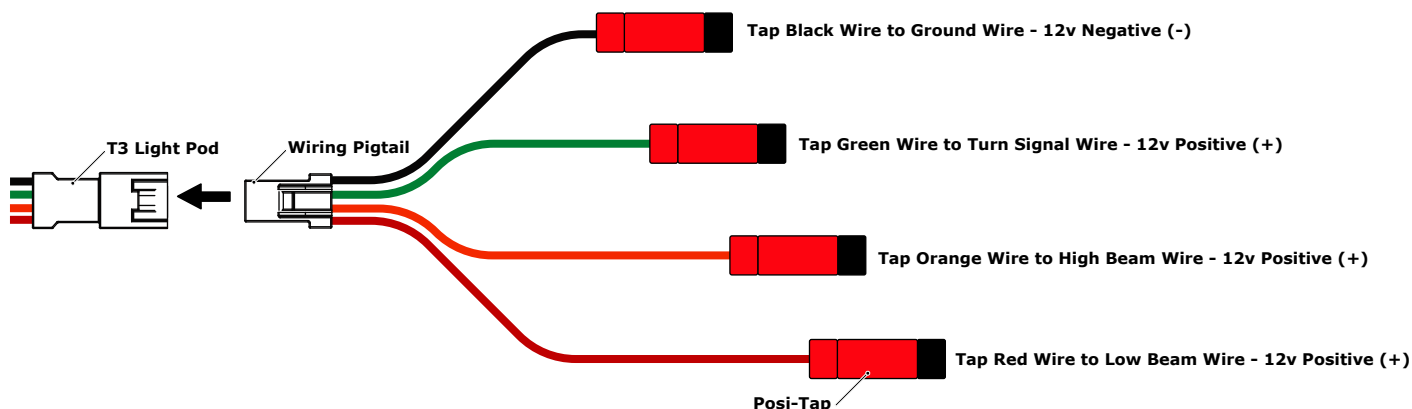

2.1 - Wiring The Pigtail

We reinvented the common turn signal to create a shockingly bright amber turn signal with an integrated dual-intensity white DRL.

Step One: Route the cable from the T3 Light Pod (a) into the motorcycle to the area of the factory head light & turn signal connectors.

Step Two: Identify the vehicle's factory Ground, Turn Signal, High & Low Beam Wires. Refer to *Section 3.1* for a list of common motorcycle wire colors, or use a voltmeter or multimeter to assist in identifying the correct wires.

Step Three: Use Posi-Tap connectors (d) to wire the Pigtail (b) to the wires identified in the previous step.

- Tap the Black Wire to Vehicle Ground Wire
- Tap the Green Wire to the Vehicle Turn Signal Wire
- Tap the Orange Wire to Vehicle High Beam Wire
- Tap the Red Wire to Vehicle Low Beam Wire or Switched Power

Step Four: Plug the Pigtail (b) into the connector of the T3 Light Pod (a).

3. Wire Identification Guide

3.1 - Common Motorcycle Wire Colors

Note: These listings are meant to be a guide, always check the circuits using a voltmeter before connecting the T3 pods to the motorcycle.

BMW

- Ground - Brown
- Left Turn Signal - Blue w/ Red Stripe
- Right Turn Signal - Blue w/ Black Stripe
- High Beam - White
- Low Beam - Yellow
- Switched Power - Red w/ Green Stripe @ Euro Socket

Harley Davidson

- Ground - Black
- Left Turn Signal - Violet
- Right Turn Signal - Brown
- High Beam - White
- Low Beam - Yellow w/ Black Stripe
- Switched Power - Red w/ Yellow Strip @ Under Seat

Honda

- Ground - Green
- Left Turn Signal - Orange
- Right Turn Signal - Light Blue
- High Beam - Blue
- Low Beam - White
- Switched Power - Pink w/ Black Stripe @ Fuse Box

Kawasaki

- Ground - Black w/ Yellow Stripe
- Left Turn Signal - Green
- Right Turn Signal - Grey
- High Beam - Red w/ Black Stripe
- Low Beam - Red w/ Yellow Stripe

KTM

- Ground - Brown
- Left Turn Signal - Violet
- Right Turn Signal - Black
- High Beam - Blue
- Low Beam - Green
- Switched Power - Yellow

Suzuki

- Ground - Black w/ White Stripe
- Left Turn Signal - Black
- Right Turn Signal - Light Green
- High Beam - Yellow
- Low Beam - Black w/ Blue Stripe

Yamaha

- Ground - Black
- Left Turn Signal - Brown
- Right Turn Signal - Green
- High Beam - Yellow
- Low Beam - Green